



INSTALLATION MANUAL



Installation Video



in more languages

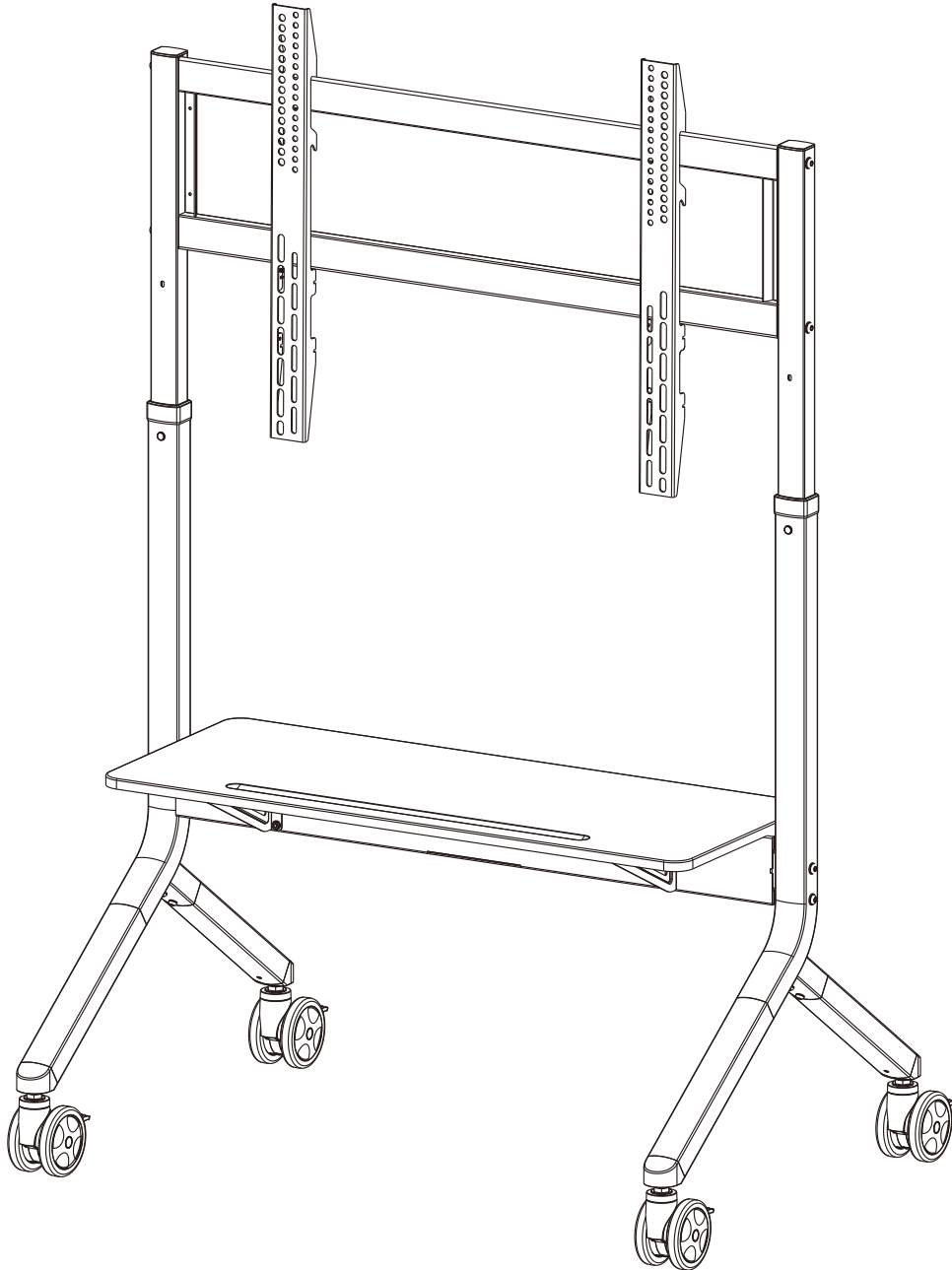

Model-P150

MOTORIZED COLLABORATION MOBILE CART



Screen Size
65"-90"



Capacity
200lbs(90.9kg)



VESA
200x200-800x600mm



Upright
13.8"(350mm)



Input voltage
100~240V 50/60HZ



Rated power
75W Max



Operation method
wireless remote control
or touch control

Contents

Contents	1/15
Caution	2/15
Assembly kit	3/15
Assembly and installation	
1. Technical specifications	4/15
2. Legs and uprights assembly	5/15
3. Tray and power crossbar assembly	6/15
4. Pillar and power crossbar assembly	7/15
5. VESA mounting frame assembly	8/15
6. VESA mounting patterns	9/18
7. VESA rails and TV assembly	10/15
8. Initialization and Touch panel instruction	11/15
9. Mounting TV onto cart	12/15
10. Cable management	13/15
11. Remote Control Pairing and Usage Instructions	14/15
12. Troubleshooting solution	15/15

Caution

Please read the entire instructions and safety guidelines prior to assembly. Failure to do so may cause personal injury, product damage, or property damage.

We want you to be completely satisfied with your new unit. If you have any questions, operational issues, or safety concerns, please contact our professional support team. We will respond promptly.

If you need assistance with product assembly or operation, or if the product arrives damaged or with missing parts, please contact local customer service immediately.

Load Capacity Specifications

- The maximum load capacity of this unit is 200 lbs (90.9 kg). It is designed for TVs with 65" to 90" screens. The shelf has a maximum load capacity of 22 lbs (10 kg).
- DO NOT exceed the maximum permissible weight.

Critical Usage Warnings

- DO NOT make any modifications not approved by the manufacturer.
- DO NOT use the unit for any purpose other than its factory-approved intended use.
- This unit contains sliding mechanisms and electronic components. For your safety, please exercise caution during use.
- We DECLARE that we CANNOT be held liable for damage or injury resulting from improper installation, incorrect assembly, or misuse.

Tip-Over Hazard Prevention

- Death or serious injury may occur if children climb on the audio/video equipment or TV cart. Placing remote controls, toys, or other attractive items on the unit may encourage climbing, potentially causing the unit to tip over.
- Placing audio/video equipment on furniture not specifically designed to support such loads may result in collapse or tip-over, causing death or serious injury—especially to children.

Tip-Over Warning

- Serious or fatal crushing injuries can result from tip-overs. To prevent this:
- Never allow children to climb, stand, hang, or play on any part of the TV or TV cart.
- Always use a tip-over restraint or securely anchor the stand to the wall.
- Note: The use of tip-over restraints can reduce, but not eliminate, the risk of tip-over.
- We declare that we cannot be held liable for any damage, injury, or death resulting from tip-over incidents.

Choking Hazard Warning

- Small parts are not suitable for children under 3 years. Adult supervision is required during assembly and use. Keep all assembly hardware away from children. Small components may pose a choking hazard if swallowed.

Environmental & Electrical Safety

- Do not expose the unit to direct sunlight or place it near heat sources.
- Do not position the product close to heating elements or open flames.
- Keep all electrical components away from liquids and moisture.
- Do not use old, damaged, or uncertified power cords to prevent electrical hazards.
- When unplugging, always grasp and pull the plug directly—never pull the power cord.







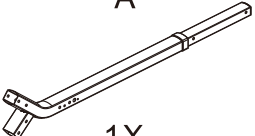
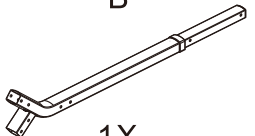
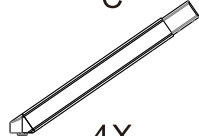
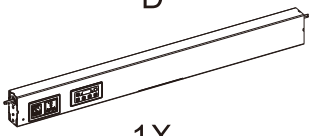
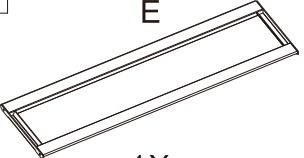

Installation & Operation Guidelines

- Always center the TV on the cart to prevent instability or damage caused by uneven weight distribution.
- Ensure the moving path is clear of obstacles to avoid collisions that may cause injury or damage.
- The power cord must have sufficient length to allow full cart movement without over-stretching, which could damage wiring and create electric shock or fire hazards.
- Do not place the cart on sloped or uneven surfaces, as this may cause tipping and result in injury or damage.
- Before moving the cart, unlock the caster brakes. Push the cart slowly and carefully to the desired location. Always lock the caster brakes after positioning.

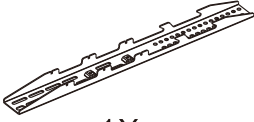
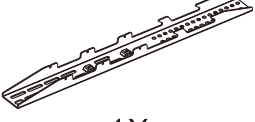
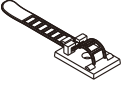
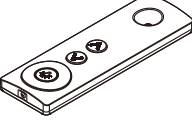





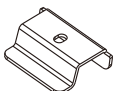





Service Notice

- No user-serviceable parts inside. Do not attempt to disassemble the unit.







Assembly Kit

1 A  1X	2 B  1X	3 C  4X	4 D  1X
5 E  1X	6 F  1X	7 G  1X	8 H  1X
9 J  2X	10 K  1X	11 L  1X	12 M  4X
13 N  1X	14 O  1X	15 P  4X	16 Q  2X

Hardware Kit

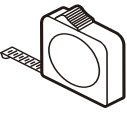
a  M8x60mm 8x	b  M6x10.5mm 8x	c  M6x14mm 8x	d  M6x20mm 2x	e  Ø8.2x1.2mm 8x	Screws for cart assembly	
f  5mm 1x						
a1  M10x15mm 4x	b1  M8x25mm 4x	c1  M6x25mm 4x	d1  M5x25mm 4x	e1  Ø6.2mm x1.5mm 4x	f1  Ø8.2mm x10mm 4x	Screws for screen assembly color:silver

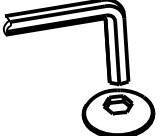
Manual

							
Tightening	Loosening	Phillips Screwdriver	Tape Measure	Adjustment	By Hand	Allen Key	+ Tightening - Loosening

1. Technical Specifications

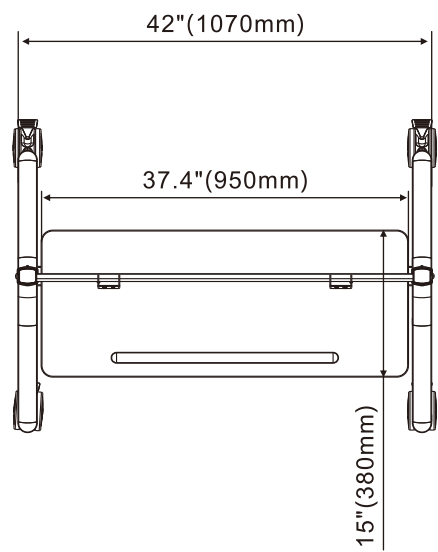
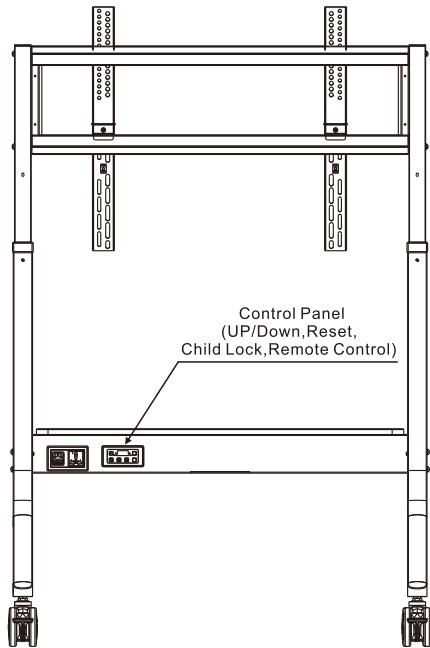
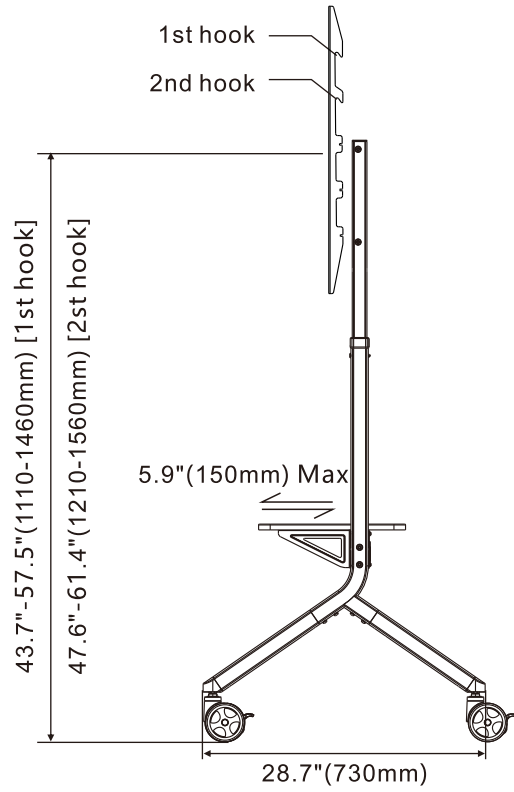
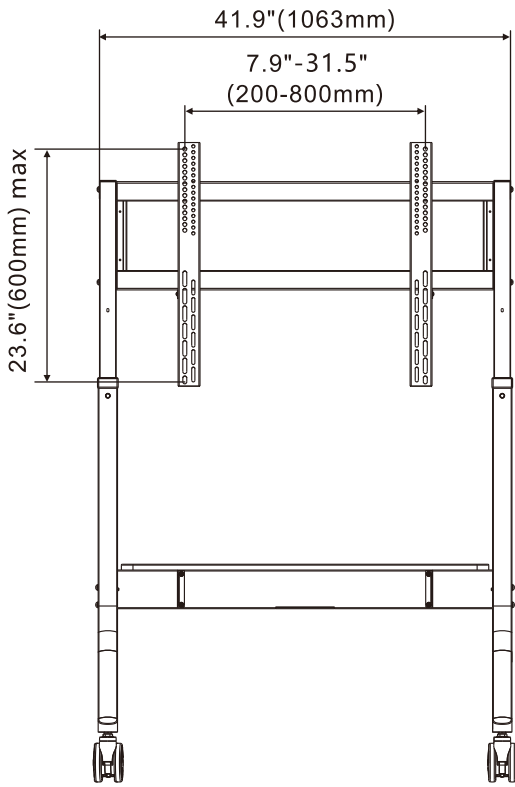

2.Legs And Uprights Assembly

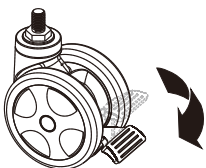

⚠
Brake

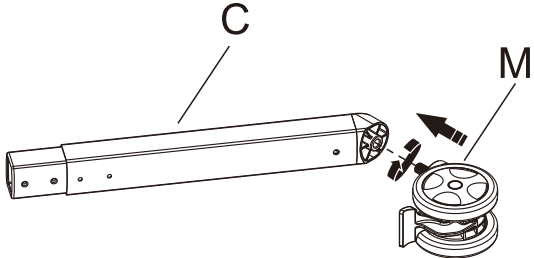

⚠
Brake the casters before assembly with legs

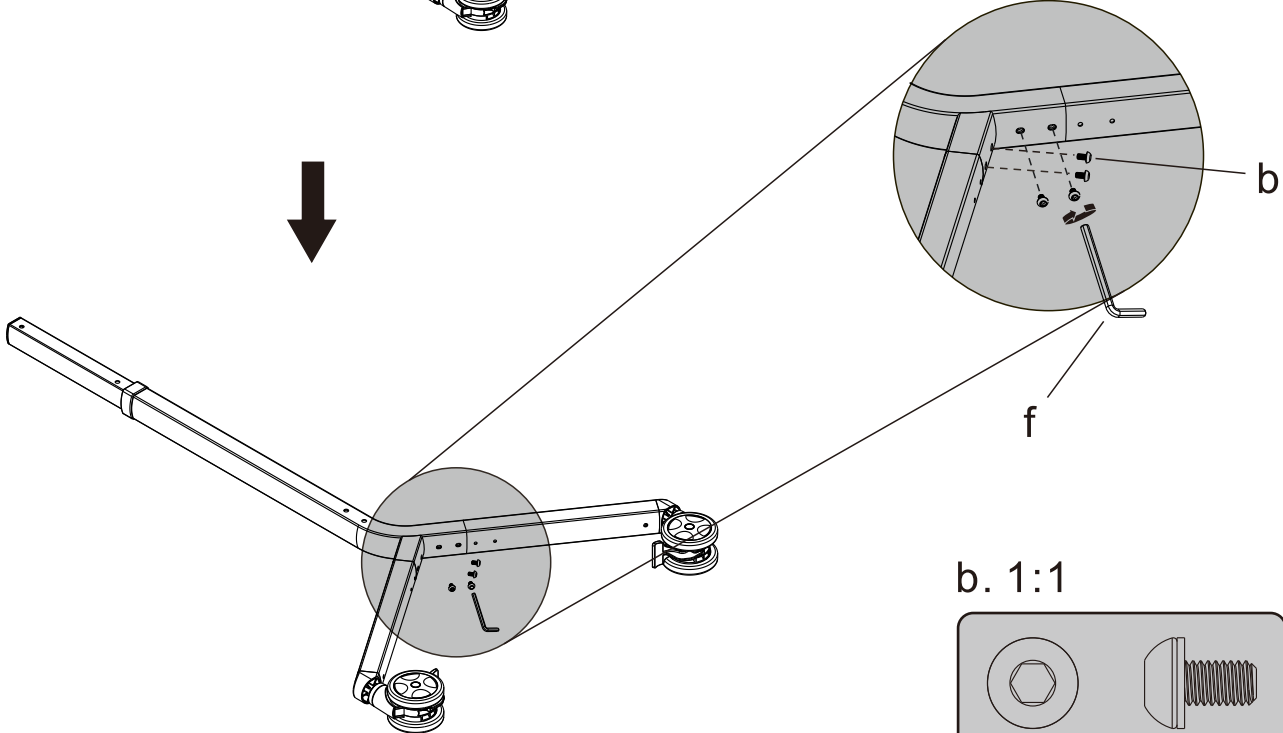
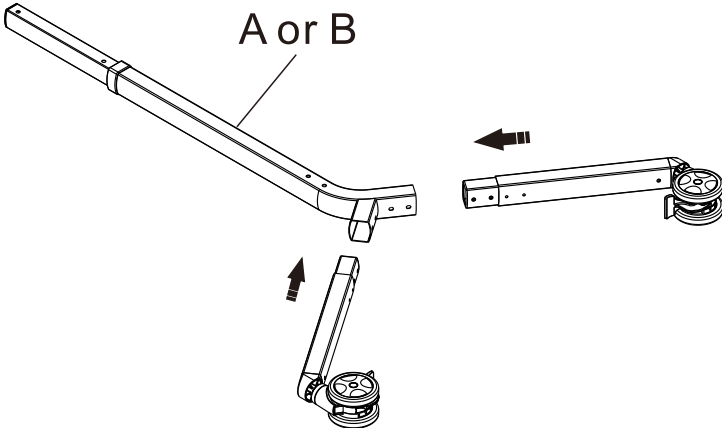

b. 1:1

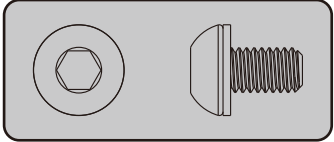

3. Tray And Power Crossbar Assembly

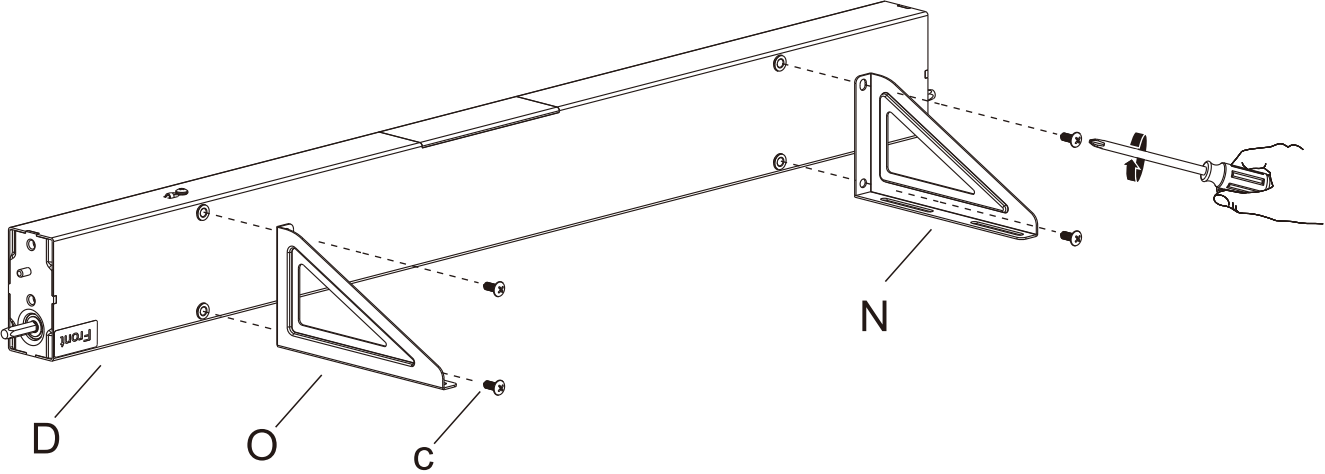

c. 1:1

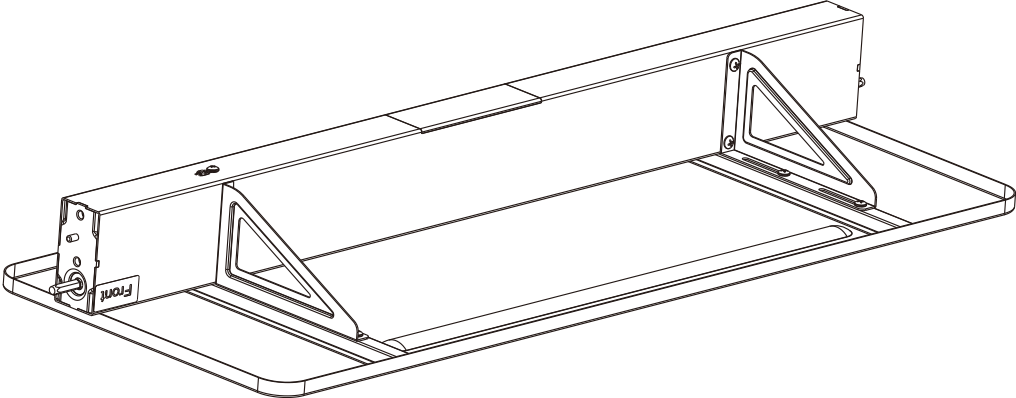
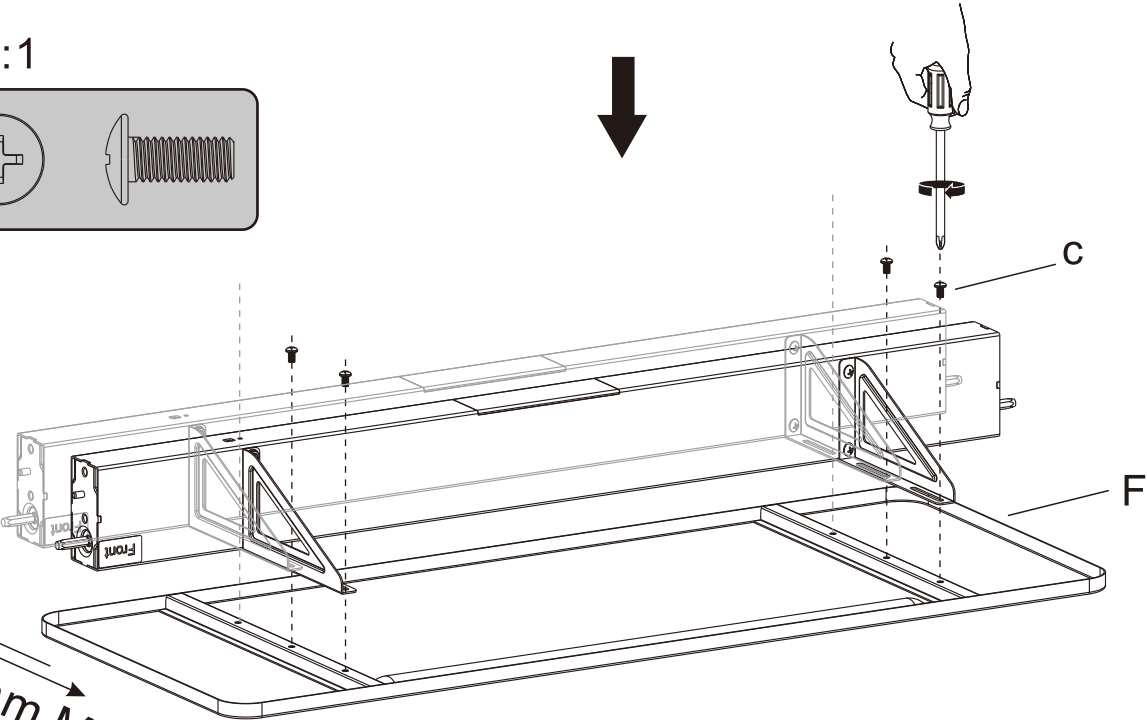
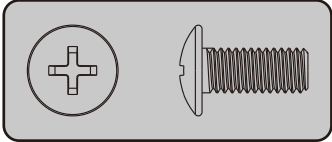

4. Pillar And Power Crossbar Assembly



The legs with the multi-hole side face inward, and place the tray correctly before assembly.

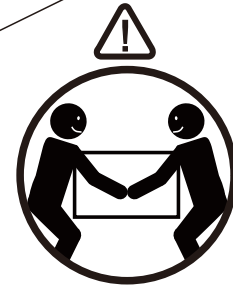
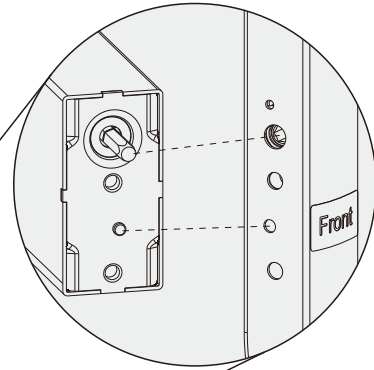
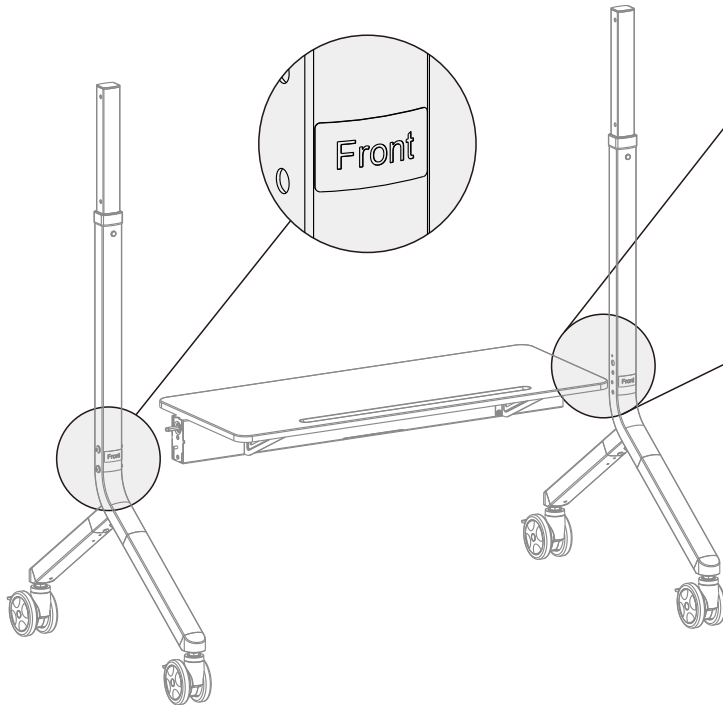

Important!
At least two persons are required for assembly.

a. 1:1

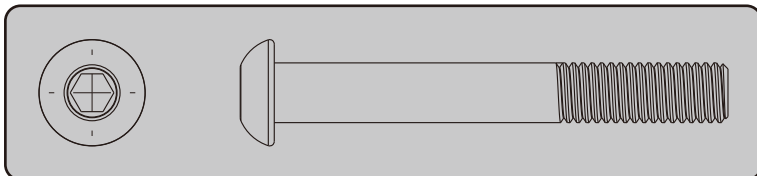

All screws must be securely tightened before use.

e. 1:1

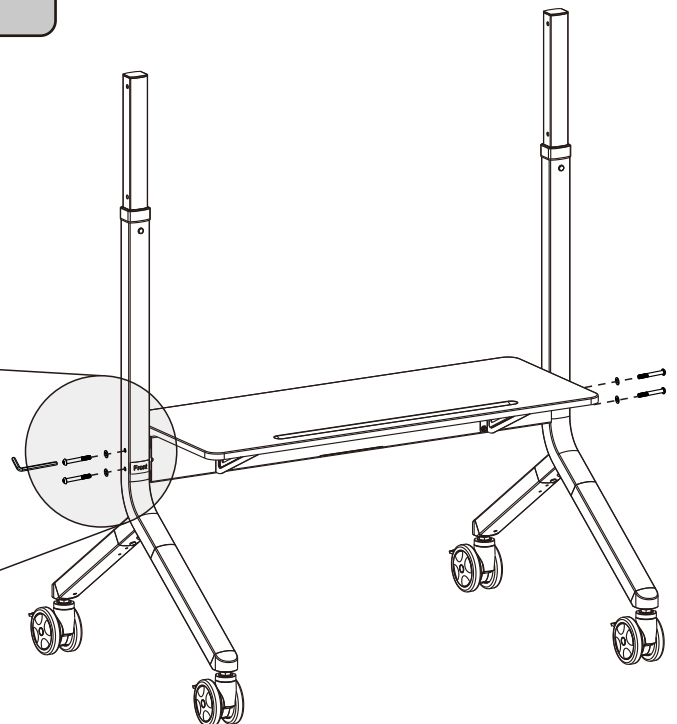
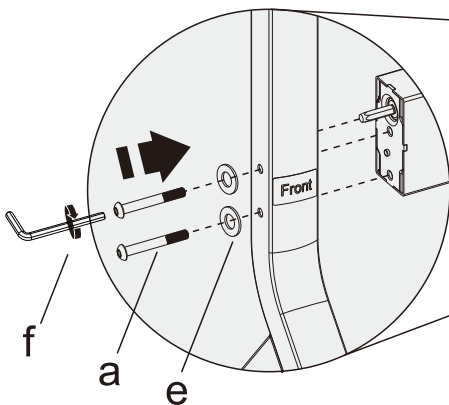
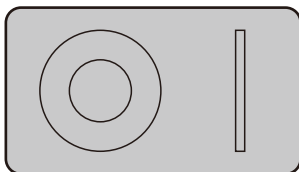

5.VESA Mounting Frame Assembly

Assembly the frame as per label instructions

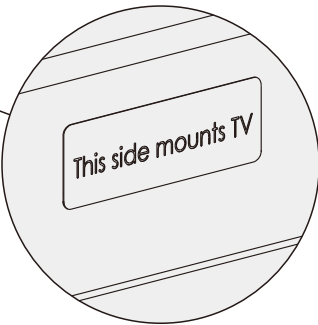
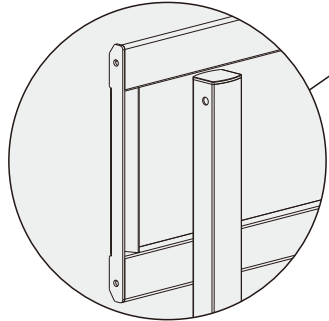
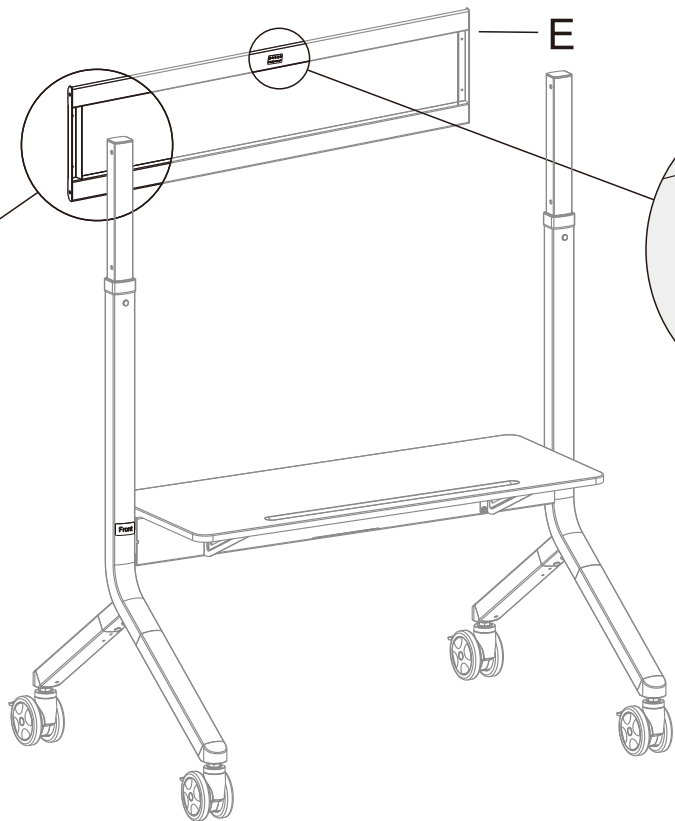

e. 1:1

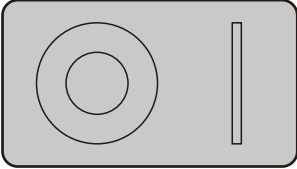

a. 1:1



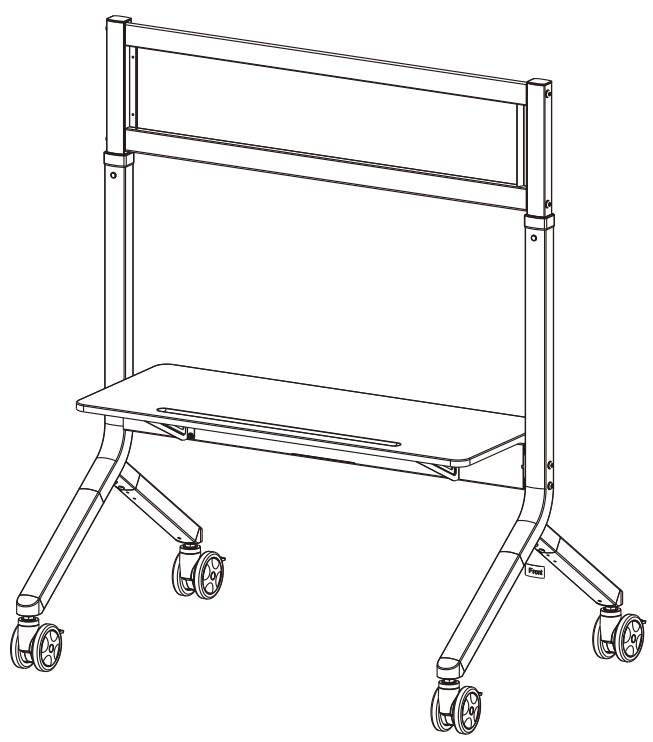
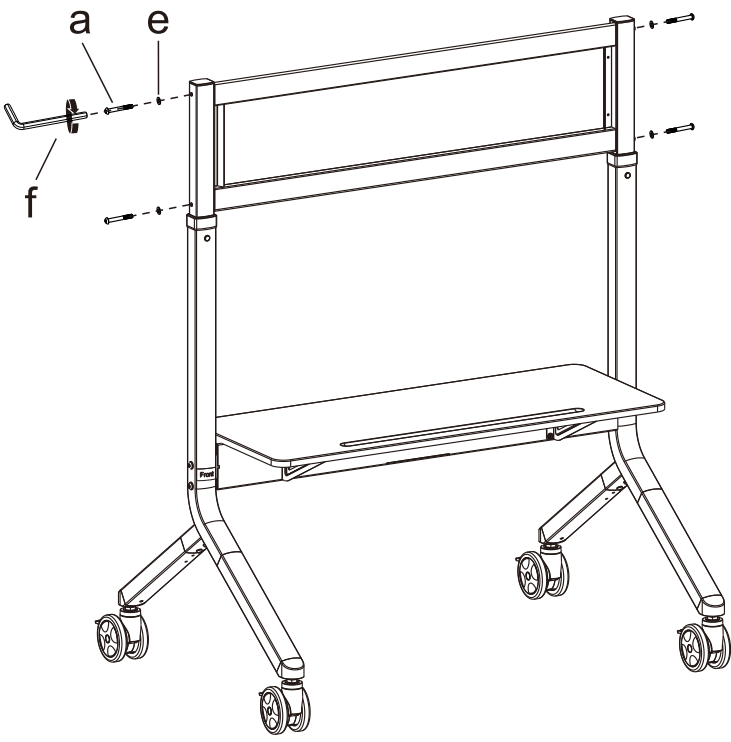

All screws must be securely tightened before use.

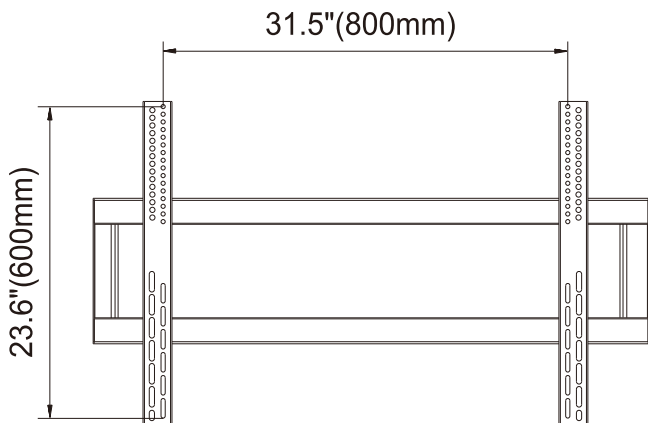
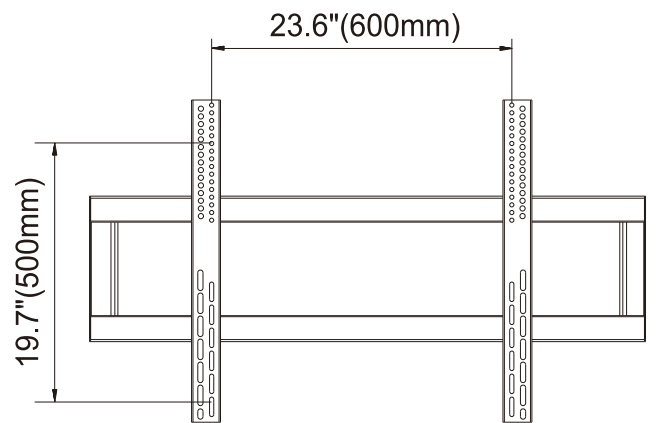
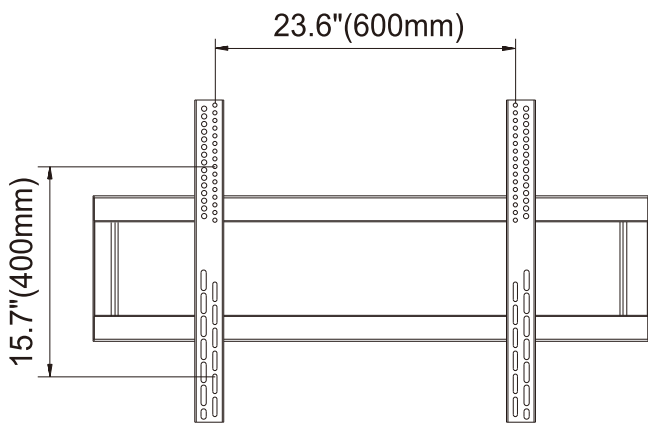
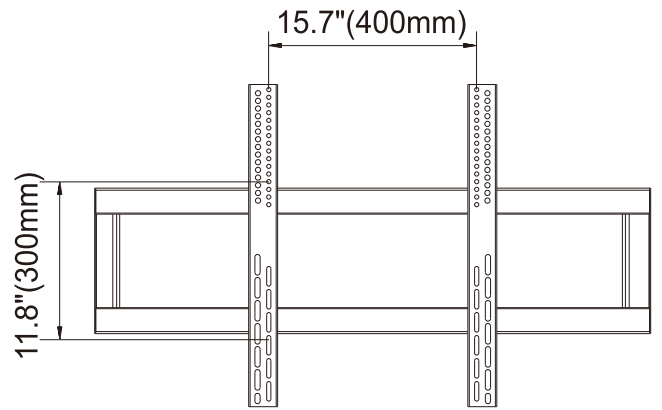
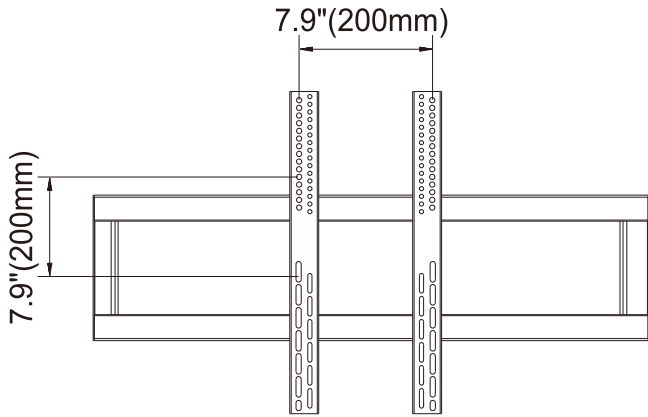

6.VESA Mounting Patterns

VESA: 200x200~800x600mm



7.VESA Rails And TV Assembly

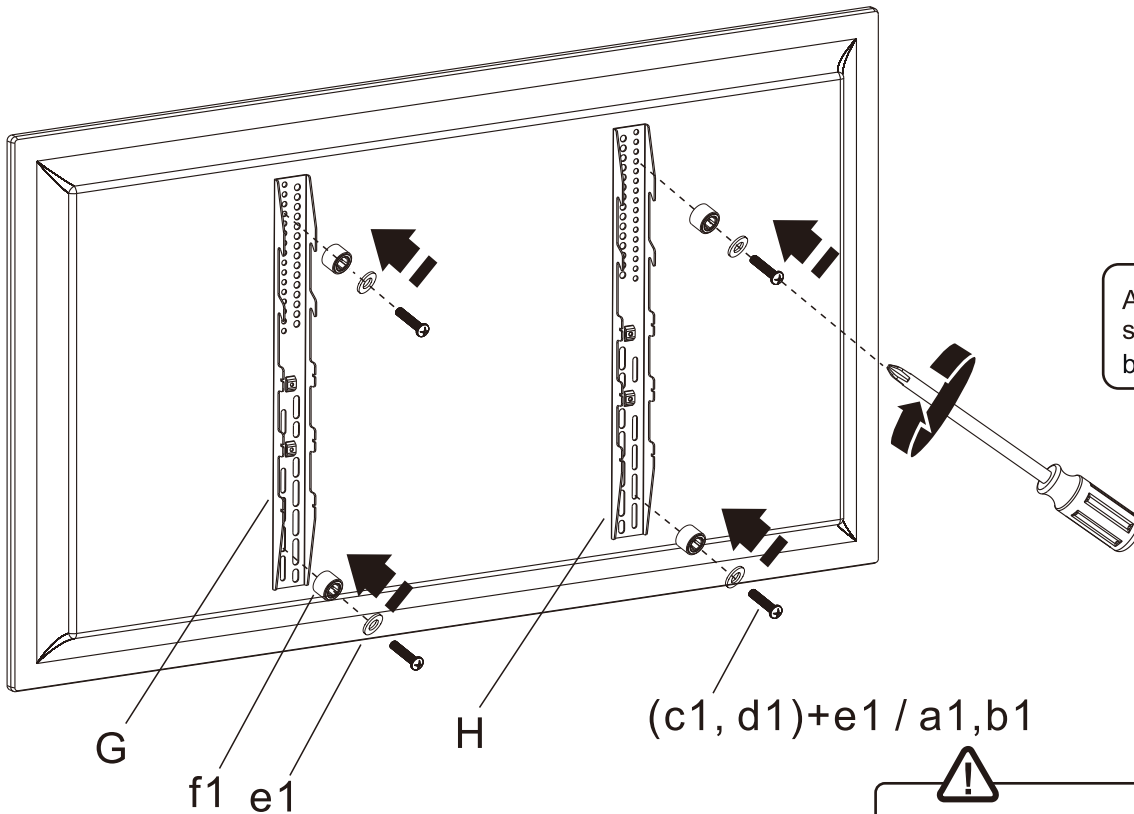



All screws must be securely tightened before use.

Based on the screw specifications, select the appropriate installation method from the three options below.

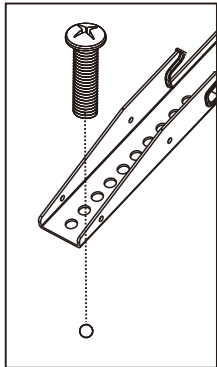
① M10x15mm(a1)

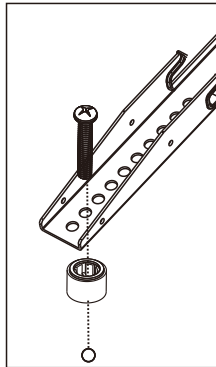
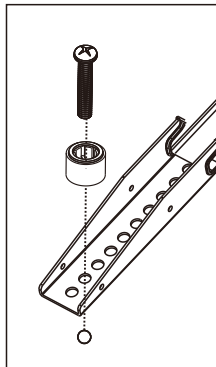

② M8x25mm(b1)+f1



③ M5x25mm(d1) +e1+f1
M6x25mm(c1)

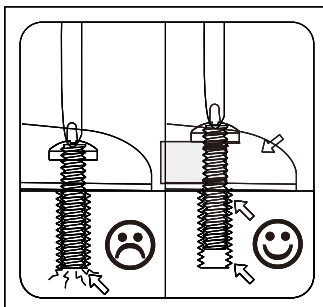
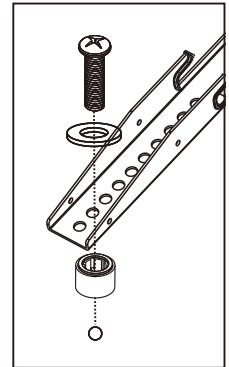
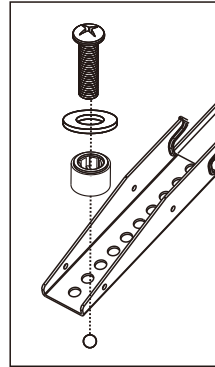

When installing your TV, if the screws are too long, you must use spacer pads to prevent damage to the TV from over-tightening.

8. Initialization And Touch Panel Instruction

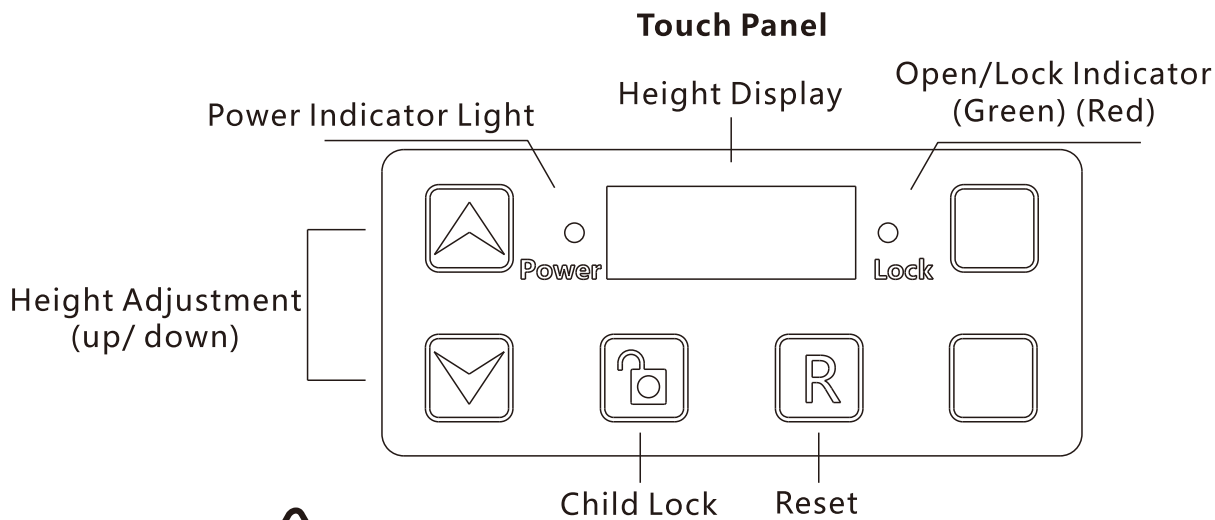

Warning! Initialization must be performed before TV is assembled.

1. Preparation: Connect the product to a 100-240 V power source in non-loaded condition.
2. Execution: Long press the reset (R) button on the touch panel . When the height display shows "1460", the product is now ready for the normal use.

Initialization settings	To initialize, press and hold the reset (R) button. "-----" flashes, indicating the procedure has started. Continue holding until the display shows "1460". This indicates the bracket has reached its top point and initialization is completed.
Child lock settings (lock/open)	To lock: Press and hold "child Lock" button. The Lock light turns red, indicating the panel is locked. To unlock: Press and hold "child Lock" button again. The Lock light turns green, indicating the panel is unlocked.
Go upward	Press and hold up button, To raise the bracket, press and hold the up button. It will rise at a constant speed. Release the button to stop the movement.
Go down	Press and hold down button, To lower the bracket, press and hold the down button. It will descend at a constant speed. Release the button to stop the movement.

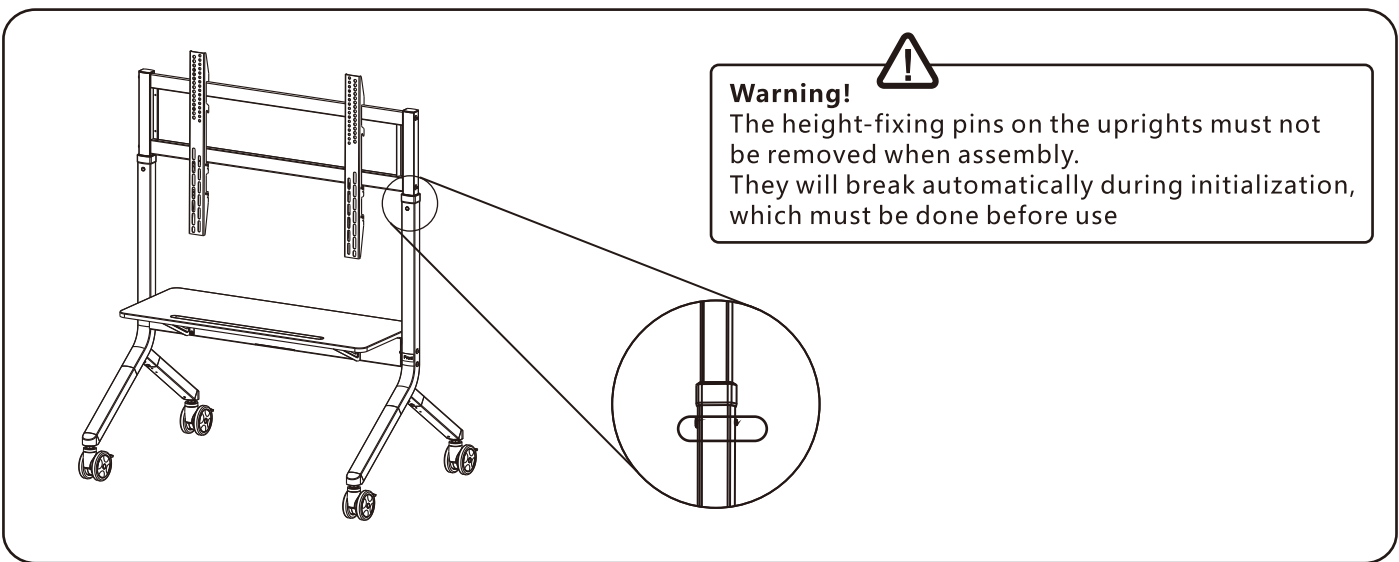

Warning!
The height-fixing pins on the uprights must not be removed when assembly. They will break automatically during initialization, which must be done before use

9. Mounting TV Onto Cart

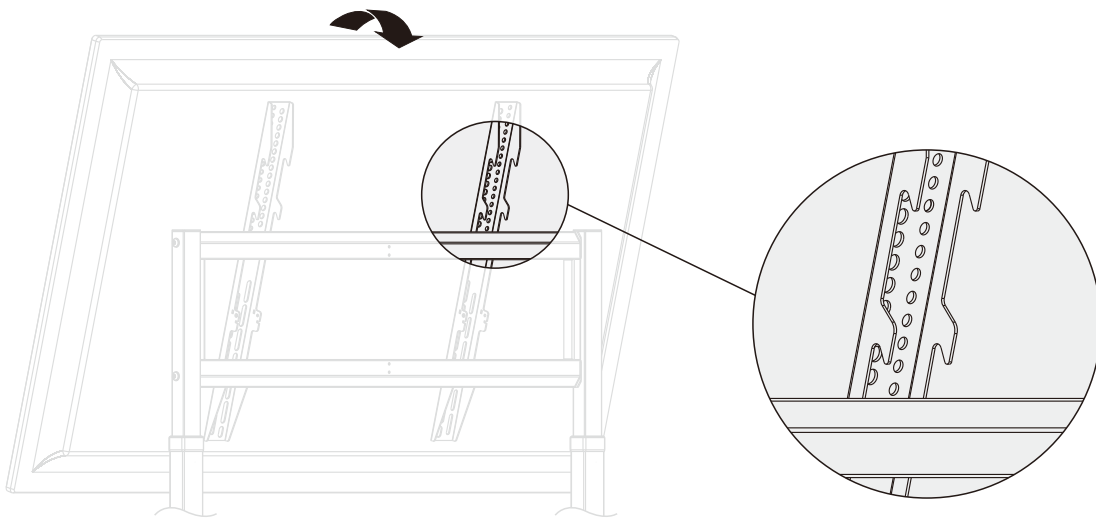



 TO prevent the TV from colliding with the bracket, please adjust the bracket to the proper height before hanging the TV set.

 When the mounting holes of the TV set are on the upper side, it is suggested to use the second position of the hook to hang the TV set.

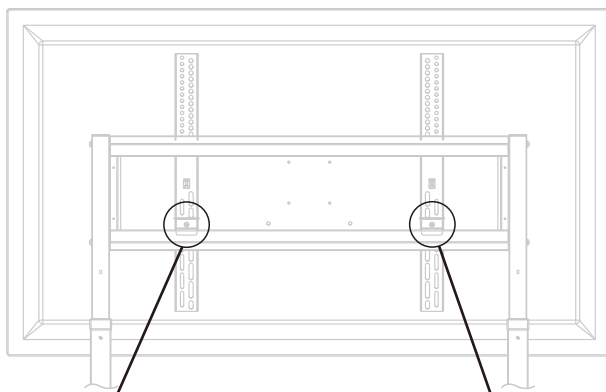
Move TV to the center position



 Two people are required to mount TV. Hold TV firmly by the bottom to avoid damage due to slide-off.

 To avoid property damage as well as personal injury, please ensure the security clips are secured firmly.

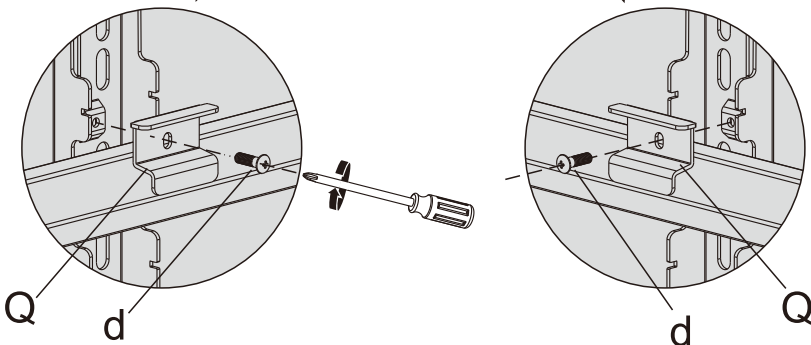

d. 1:1

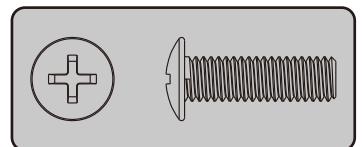

10.Cable Management

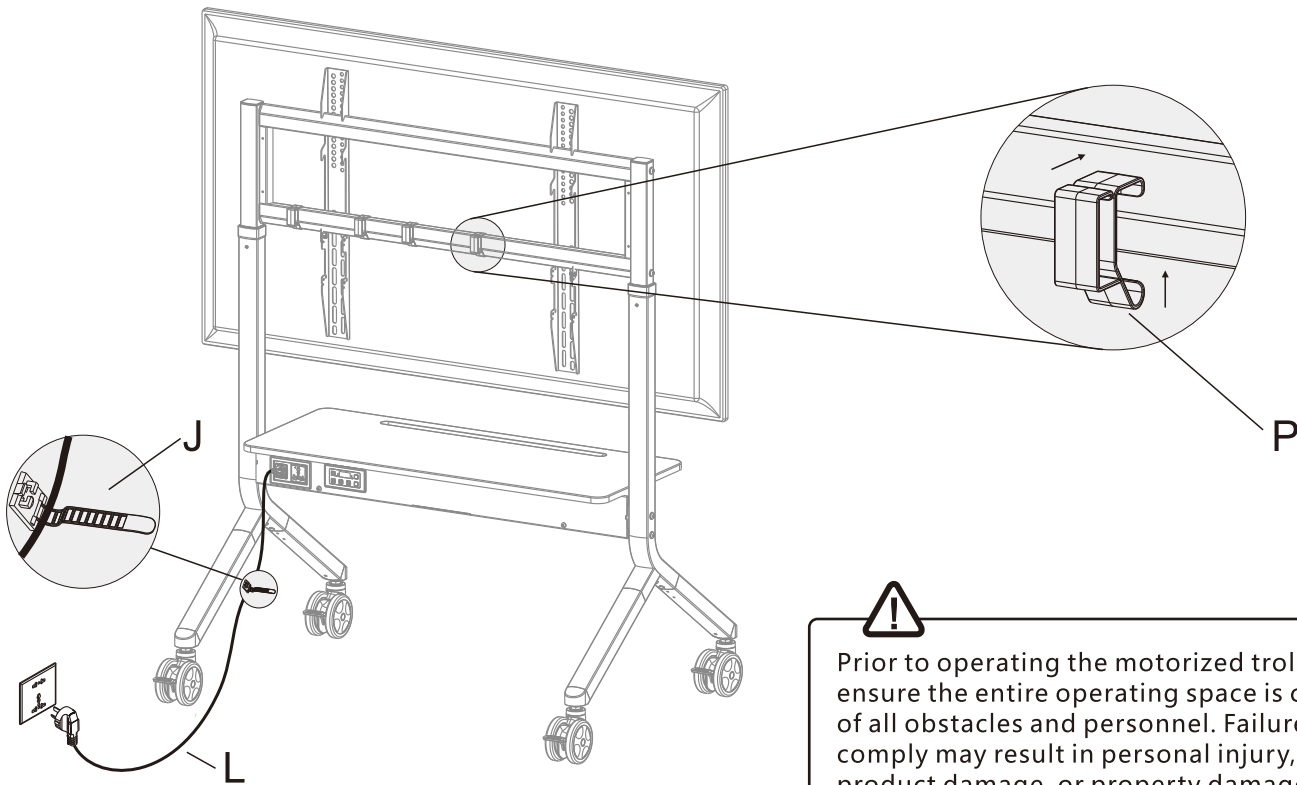

!
Prior to operating the motorized trolley, ensure the entire operating space is clear of all obstacles and personnel. Failure to comply may result in personal injury, product damage, or property damage.

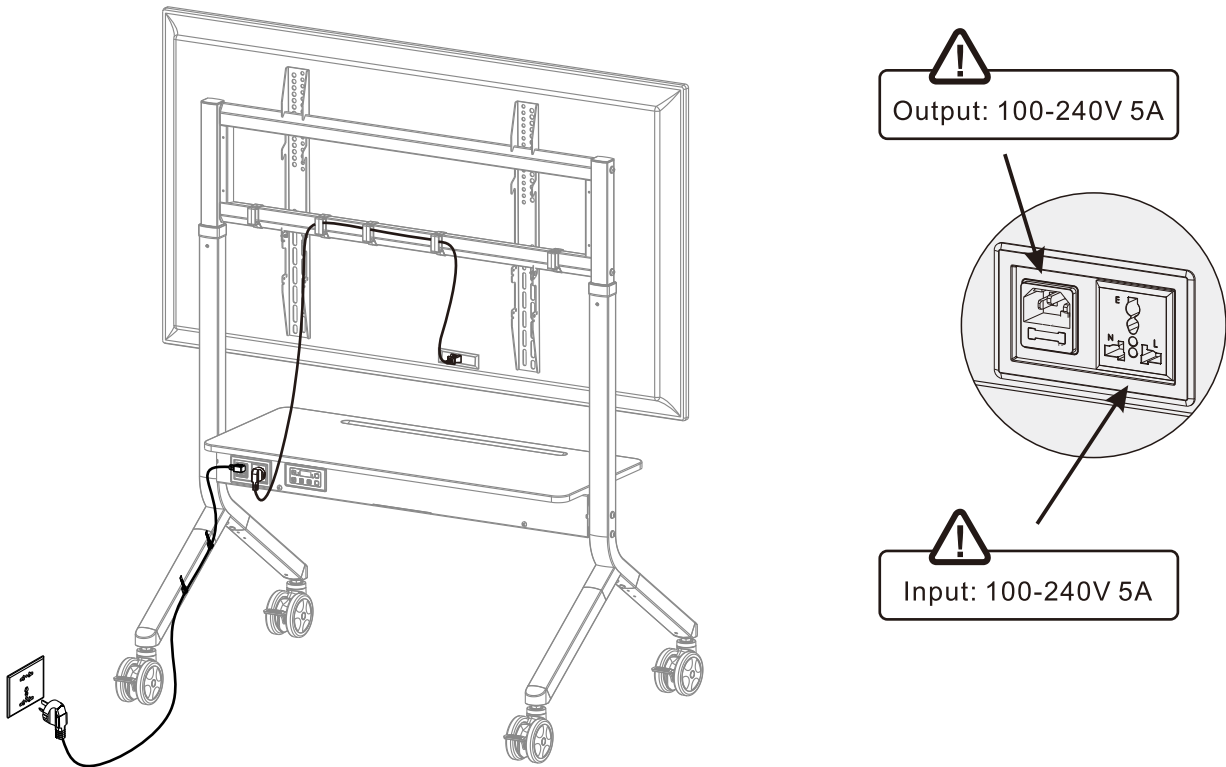

11. Remote Control Pairing And Usage Instructions

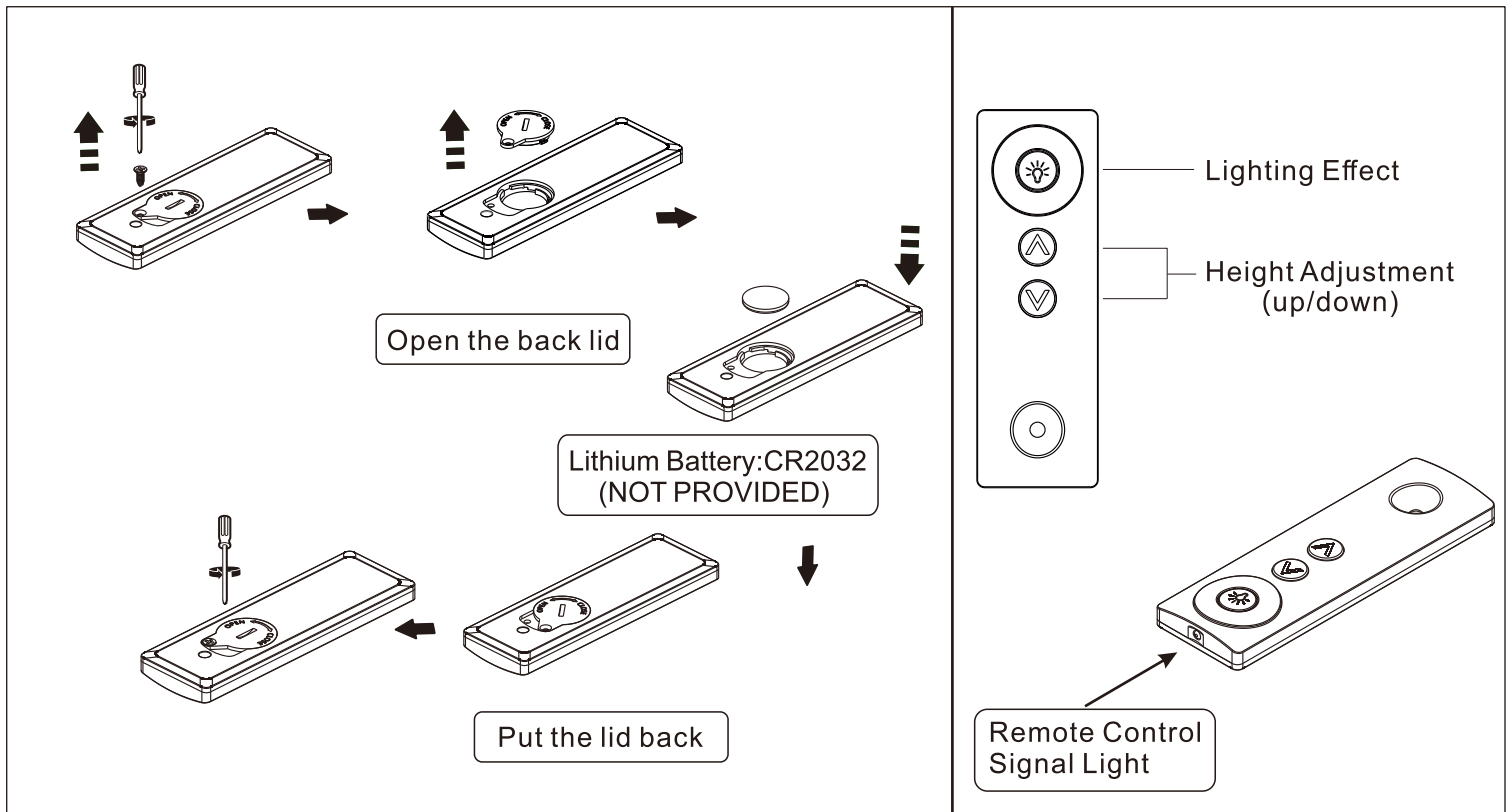

1. How to Pair the Remote Control with the Touch Control Panel

- Unplug the power cord from the power outlet.
 - Press and hold the "light effect" button until the remote control signal light starts flashing.
 - Continue holding the "light effect" button and reconnect the power cord. Release the button once the signal light turns off.
- The remote control has now been successfully paired with the touch control panel.

2. Height adjustment

- Press and hold the up button to raise the stand.
Press and hold the down button to lower the stand.

CAUTION – Remote Control Battery Safety

- Battery type: CR2032 lithium coin cell.
- Due to shipping restrictions on lithium batteries, the remote control may be shipped without a battery in certain countries or regions.
- Do NOT disassemble the remote control. Doing so may cause malfunction or permanent damage.
- Do NOT drop the remote control or expose it to direct sunlight, extreme heat, moisture, or liquids.
- Remove the battery if the remote control will not be used for an extended period to prevent damage from battery leakage.
- If the remote control does not operate properly, remove the battery and reinstall it after 30 seconds. If the issue persists, replace the battery with a new one.

12. Troubleshooting Solution

Malfunction Code Guidance

If the TV cart does not operate normally, a malfunction code will flash on the control panel display to indicate a possible issue. Follow the recommended actions below to resolve the problem.

If the issue persists after performing the suggested steps, please contact authorized service personnel or your local distributor for assistance.

Trouble shooting Solution

Code	Description	Solution
E01	Power circuit is disconnected	The power crossbar requires service, and it must be returned to the factory or an authorized service center for repair.
E02	Over-loaded Condition	A. Immediately reduce the load on the stand to a safe level B. Do not attempt to reuse the unit. The power crossbar must be returned to the factory for professional repair.
E03	Status: Obstacle Detected	Please check the movement path and clear any obstructions
E04	Motor overheated	A. Allow the motor to cool down for at least 18 minutes before resuming operation B. To perform a power cycle, disconnect the unit from its power source, then reconnect and restart it
E05	Low voltage	Input voltage is too low. Please check the power supply to meet the specified requirements (100-240 V)



HONGJIE GROUP



N.W. / P.N. / 正味重量: 26.2 kg(57.6 lbs)
G.W. / P.B. / 総重量: 29.3 kg(64.5 lbs)
MEAS / DIM / 測定: 109.5x44.5x15cm
MADE IN CHINA / FABRIQUÉ EN CHINE / 中国製

Parent Company :
Kunshan Hongjie Electronics Co.,Ltd
No.1050, Fu Chun Jiang Road,Economic Development Zone ,
Kunshan City , Jiangsu. China.215333

Manufacturer :
Anhui Hongjie Ergonomic Technology Co.,Ltd
No.10 Guangping Road,Economic Development Zone ,
Guangde,Xuancheng City , AnHui. China.242200

Email: info@NBergonomic.com www.NBergonomic.com

The manufacturer reserves the right to modify the content
of this manual at any time and without prior notice.
执行标准: Q/320583AJHJ 001-2025
Perform Standard:Q/320583 AJHJ 001-2025(Enterprise Standard)